

LULLABY op. 38 n°1 Grieg  
 Choreography Malkovsky 1922  
 Notation Karin Hermes-Sunke and Suzanne Bodak 1997

tempo 1

1 music

2

3

4 march toward her Destiny

2/4 ♩ = m

B = Baby

5

6 the mother invokes the Earth

7

8 she invokes the Heavens

tempo 1: bars 1-48 ♩ = m ≈ 72

tempo 2: bars 49-67 ♩ = m ≈ 104

tempo 1: bars 71-86 ♩ = m ≈ 72

# LULLABY

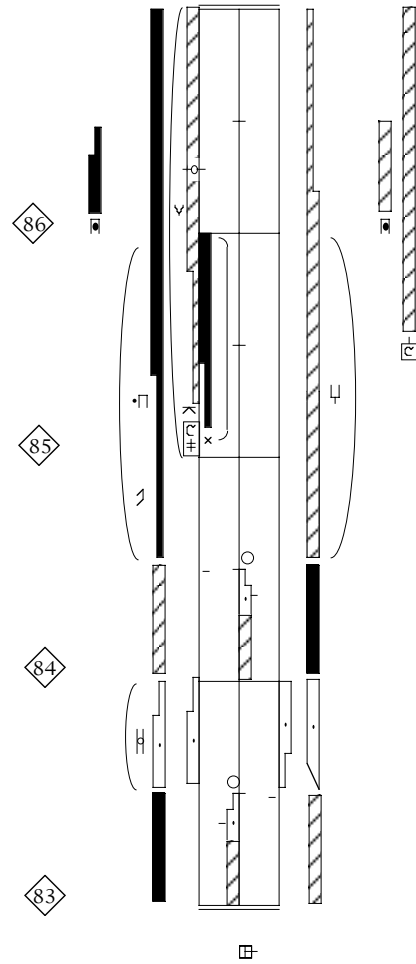

© Notation by  
K. Hermes-Sunke and S. Bodak

# LULLABY

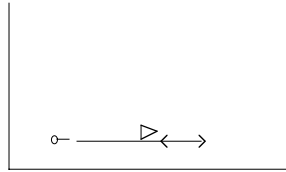

1 - 9

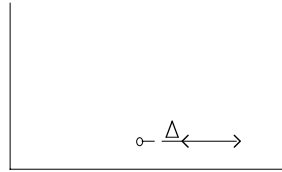

10 - 16

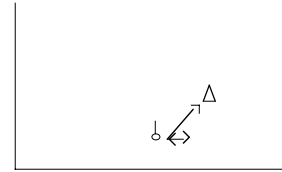

17 - 20

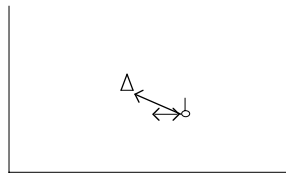

21 - 24

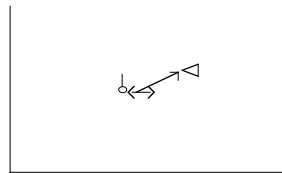

25 - 28

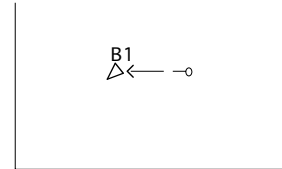

29 - 32

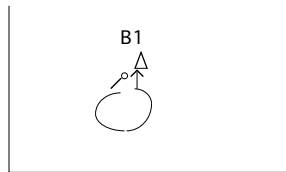

33 - 36



37 - 40

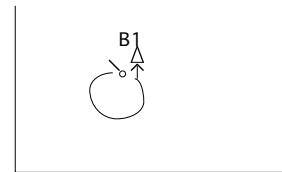

41 - 44

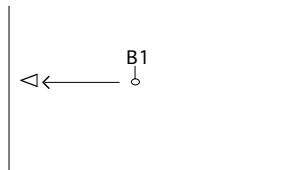

45 - 53

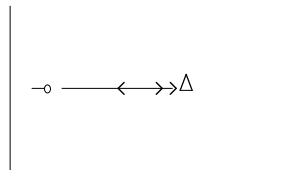

54 - 62

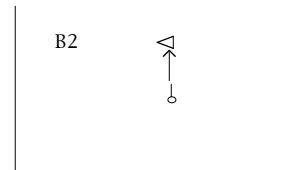

63 - 70

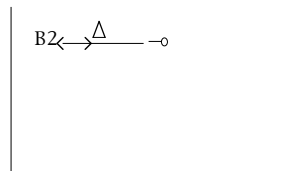

71 - 79

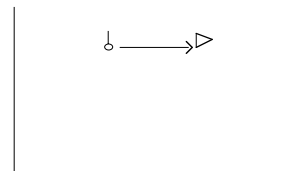

80 - 86